

SafeZone

Safety Laser Scanner Overview

Principles of Operation

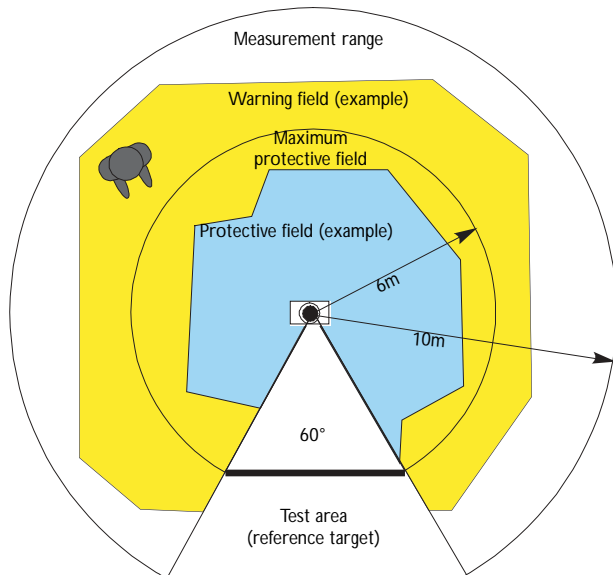

The SafeZone safety laser scanner has been designed for industrial use. Its task is to detect access of persons to dangerous areas and stop the hazardous movement of a machine in this area. A signal is triggered as soon as a person or object enters the monitored area:

- If a person or object is present within the **warning field** the SafeZone safety laser scanner switches a relay contact at the corresponding signal output. This signal can be used for acoustic and optical warnings. Warnings are to indicate that the hazardous area is to be left before the protective field is activated, and the SafeZone safety laser scanner OSSDs issue a stop signal that would trigger a machine stop.
- If a person or object is present within the **protective field** the SafeZone safety laser scanner switches two independent relay contacts. This signal must lead to an immediate switching off of the dangerous machine movement.

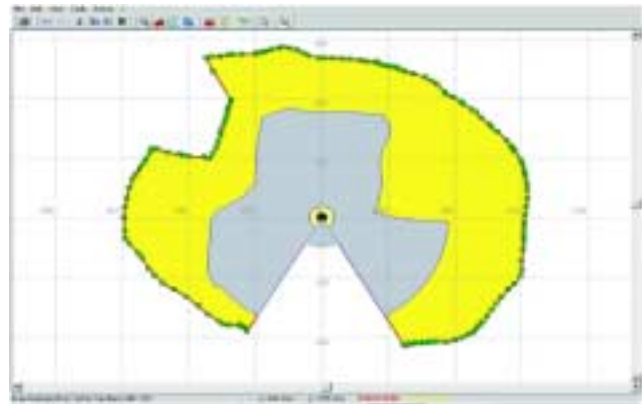

Configuration of the SafeZone's Warning and Safety Fields are accomplished through Allen-Bradley's SCD (Safety Configuration and Diagnostic) Windows-based software. Warning and Safety zones are easily configured through the use of the PC's mouse. Simply click and drag points along the perimeter of the particular zone to shape the contour of the perimeter.

Areas of Protection

The SafeZone is suitable for personnel protection applications on:

- Stationary machinery
- Robot assembly cells
- Hazard zones—overhead motion
- Mobile transport vehicles

Automatic Guided Vehicles (AGVs)

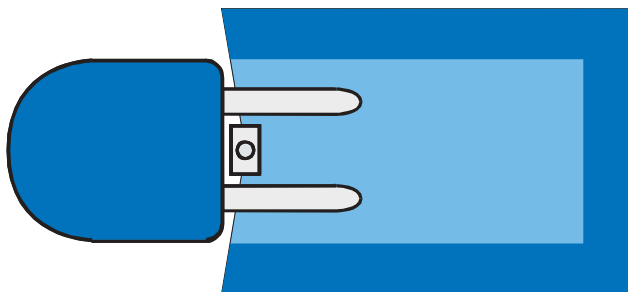

The SafeZone safety laser scanner is designed to detect fixed objects (walls, columns) as well as moving objects (people, AGVs).

The SafeZone is typically mounted on the front of a mobile vehicle—in each direction of travel. Any object in the path of the moving vehicle, of sufficient resolution, is detected.

The SafeZone can be configured with both an outer warning field and an inner safety field. The outer warning field has a separate

nonsafety relay output which can connect to an alarm, indicating when the warning field has been broken. Penetration of the safety field causes the dual safety relay outputs of the SafeZone to change state and stop the vehicle's movement.

It is necessary to properly mount the SafeZone and then determine the size of the safety field based on a safety distance formula. This information is detailed in the *SafeZone Installation Instruction* manual.

SafeZone Safety Laser Scanner



Description

The SafeZone Safety Laser Scanner is an optoelectronic device that uses the diffuse reflection of emitted infrared light to determine the intrusion of a person or object within a defined area. A rotating deflection unit periodically emits Class 1 infrared laser light pulses over a 300° angular range to create a detection zone which is two dimensional. The reflected light is processed by the SafeZone, which will send a stop signal by switching the state of its safety relay outputs, if it is determined that a person or object is within the predefined detection zone.

Two zones can be created within the maximum scanning range of the SafeZone through the use of the SafeZone's Windows based software. The "Safety Zone" is configurable for a 6m (19.7ft) radius and the "Warning Zone" up to a 10m (32.8ft) radius.

The SafeZone can be used in stationary applications for horizontal detection in a defined protection zone, in vertical applications for whole body access detection, and on mobile safeguarding applications—AGVs (Automated Guided Vehicles).

The maximum value of the machine's stopping time plus the SafeZone's response time must be calculated so that no person can gain access to a hazard point before the dangerous motion has ceased.

Features

- 300° scanning angle
- Two programmable zones (Safety/Warning)
- Safety relay outputs
- Robust IP65 housing

Specifications



Safety Category	Type 3 ESPE acc. to EN 61496-1
Laser Protection Class	IEC 60825 Laser Class 1 (eye safe)
Measurement & Toler. Range	0 to 10m (0 to 32.8ft)
Range for a Safe Detection of Objects the "Nominal Leg"	0 to 6m (0 to 19.6ft) (includes safety supplement)
Protective Field Res. Time	280ms
Maximum Angle	300°
Wavelength	905nm
Pulse Frequency	5.76KHz + 5%
Scanning Frequency	8Hz + 5%
Scanning Angle	300°
Resolution	70mm (2.8in) at 6m (19.6ft)
Point Resolution	0.5°
Optics (Co-axial Transmitter and Receiver Optics)	
Laser Beam Divergence	15 mrad (0.86°)
Focal Length	30mm (1.18in)
Lens Diameter	30mm (1.18in)
Power Supply	
Operating Voltage	24V DC ± 25% (via a safety insulating transformer acc. to IEC 742)
Switch on Current	2A for 100ms
Power Consumption	24W total
Housing and Environmental Resistance	
Material	Aluminium
Enclosure Rating	IP 65
Weight	3.0kg
Operating Temperature	0°C ... 50°C (32°F to 122°F)
Storage Temperature	-20°C ... 70°C (-4°F to 158°F)
Interfaces	
Data Interfaces to Computer	RS 232: 9600 baud, 8 data bits, 1 stop bit, no parity
Signal Outputs for Warning Field, OSSD 1, OSSD 2	Potential-free relay outputs, max. 2A, max. 30V, purely resistive load, number of operations; 2 million

Product Selection

1. Safety Laser Scanner

Catalog Number	Description
442L-SSFZN	SafeZone Safety Laser Scanner, 24V DC

2. Cordsets

Catalog Number		Description			Catalog Number		Description		
442L-SCPWR		Power & Outputs 5m (16.3ft)	 <i>View of the Soldered Side of the 8-Pin Socket—Connects to SafeZone. Opposite End Individual Leads Pre-stripped</i>		442L-SCCFG		Communication Cable for Configuration of Zones 5m (16.3ft)	 <i>View of the Soldered Side of the 14-Pin Socket Configuration Cable—Connects to SafeZone. Opposite End 9-Pin D-Sub Connector</i>	
Pin #	Signal	Explanation	Marking	Color	Pin #	Signal	Explanation	Direction	Level
1	24V	24V DC supply	+	Brown	A	GND	Ground, RS 232	---	---
2	GND24	Ground	-	Blue	C	RTS	RS 232: Ready to send	Output	24V
3	OSSD 2.1	Relay contact for protective field 2.1	S2	White	E	CTS	RS 232: Clear to send	Input	24V
4	OSSD 2.2	Relay contact for protective field 2.2	S2	Grey	G	TxD	RS 232: Transmit data	Output	24V
5	OSSD 1.1	Relay contact for protective field 1.1	S1	Black	J	RxD	RS 232: Receive data	Input	24V
6	OSSD 1.2	Relay contact for protective field 1.2	S1	Green	L	---	No connection	---	---
7	Warning field 1.1	Relay contact for warning field 1.1	A	Red	M	RES	Reset (active LOW)	Input	24V
8	Warning field 1.2	Relay contact for warning field 1.2	A	Pink	N through U		No connection	---	---
	FE	Functional Ground (Shield)	FE	Thick Black					

Note: The SafeZone Safety Laser Scanner is a Type 3 device with two N.O. relay outputs. The SafeZone's OSSD outputs can be connected directly to the final switching devices, FSDs, (contactors) of the guarded machinery. In order to attain a Category 3 system, the SafeZone must be connected through a safety relay module which monitors both FSDs.

3. MSR 126 Relay—Optional

Relay	Safety Outputs	Auxiliary Outputs	Reset	Input	Power Supply	Catalog Number
	2 N.O.	None	Automatic/Manual	Dual Channel (MSR126.1T)	24V AC/DC	440R-N23114
					115V AC	440R-N23113
					230V AC	440R-N23112
			Monitoring Manual	Dual Channel (MSR126.1R)	24V AC/DC	440R-N23120
					115V AC	440R-N23119
					230V AC	440R-N23118

SafeZone

Safety Laser Scanner

Product Selection (continued)

3. MSR 127 Relay—Optional

Relay	Inputs	Safety Outputs	Auxiliary Outputs	Power Supply	Type	Reset	Catalog Number
	1NC, 2NC, or Light Curtain or Laser Scanner	3 N.O.	1 N.C.	24V AC/DC	MSR127TP	Automatic/Manual	440R-N23132
					MSR127RP	Monitored Manual	440R-N23135
				115V AC	MSR127TP	Automatic/Manual	440R-N23131
					MSR127RP	Monitored Manual	440R-N23134
				230V AC	MSR127TP	Automatic/Manual	440R-N23130
					MSR127RP	Monitored Manual	440R-N23133

3. MSR 131 Relay—Optional

Relay	Inputs	Safety Outputs	Auxiliary Outputs	Power Supply	Catalog Number
	1 N.C. or 2 N.C. or Safety Mat or Light Curtain or Laser Scanner	3 N.O.	2 N.C. 2 PNP Solid State	24V AC/DC	440R-C23139
				115V AC	440R-C23137
				230V AC	440R-C23136

3. MSR 138 Relay—Optional

Relay	Inputs	Safety Outputs	Safety Delayed Outputs	Time Delay	Power Supply	Catalog Number
	1 N.C. or 2 N.C. or Light Curtain or Laser Scanner	2 N.O.	3 N.O. (MSR138DP)	0.15 – 3s	24V AC/DC	440R-M23143
					115V AC	440R-M23141
					230V AC	440R-M23140
				0.5 – 10s	24V AC/DC	440R-M23147
					115V AC	440R-M23145
					230V AC	440R-M23144
				1.5 – 30s	24V AC/DC	440R-M23151
					115V AC	440R-M23149
					230V AC	440R-M23148
			0.15 – 3s	2 N.O. 1 N.C. (MSR138.1DP)	24V AC/DC	440R-M23084
					115V AC	440R-M23082
					230V AC	440R-M23081
					24V AC/DC	440R-M23088
					115V AC	440R-M23086
					230V AC	440R-M23085
1.5 – 30s	24V AC/DC	440R-M23092				
	115V AC	440R-M23090				
	230V AC	440R-M23089				

Product Selection

4. Accessories—Optional

	Products	Catalog Number
	Power supply: Input—85...265V AC Output—24V DC, 3 Amps	1794-PS3

5. Typical Wiring Diagrams

Wiring SafeZone Outputs to a Safety Relay Module

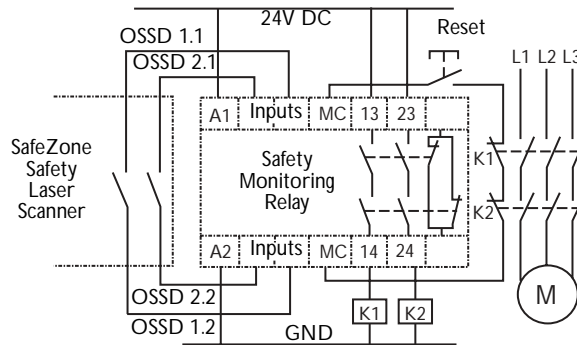

SafeZone OSSDs directly to FSDs (contactors)—Category 1 System

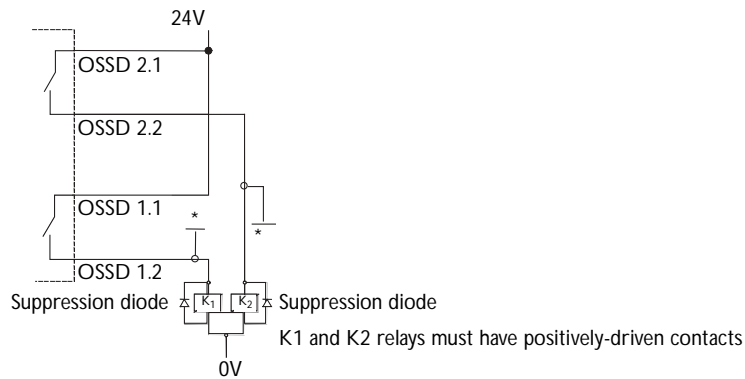

SafeZone Warning Field Output

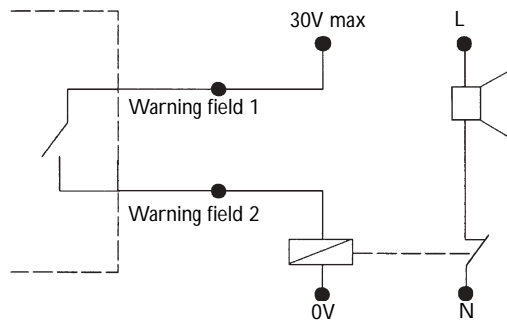

SafeZone

Safety Laser Scanner

Dimensions—mm (inches)

